

# Actuator Dimensions

PART-TURN ACTUATOR x-matic



**DREHMO**  
VALVE ACTUATORS

Actuator DPIM Ex, DPIMR Ex Models	75/150/299	300/450	600/900	1200/1800
Weight [kg]	32	34	40	45
Dimensions [mm]				
L max.	623			
T4 max.	408			
H max.	439	456	475	540
D1	Ø160			
D2 max.	Ø127			
H1a	439	456	475	540
H1b	436	453	472	537
H2	226	244	263	328
H4	163	180	199	264
L2	238			
L3	560			
L5	63			
T1	162			
T2	299			
T3	178			
T4a	407			

1) Electrical connection size "5" as standard. Options available, refer to page 4.

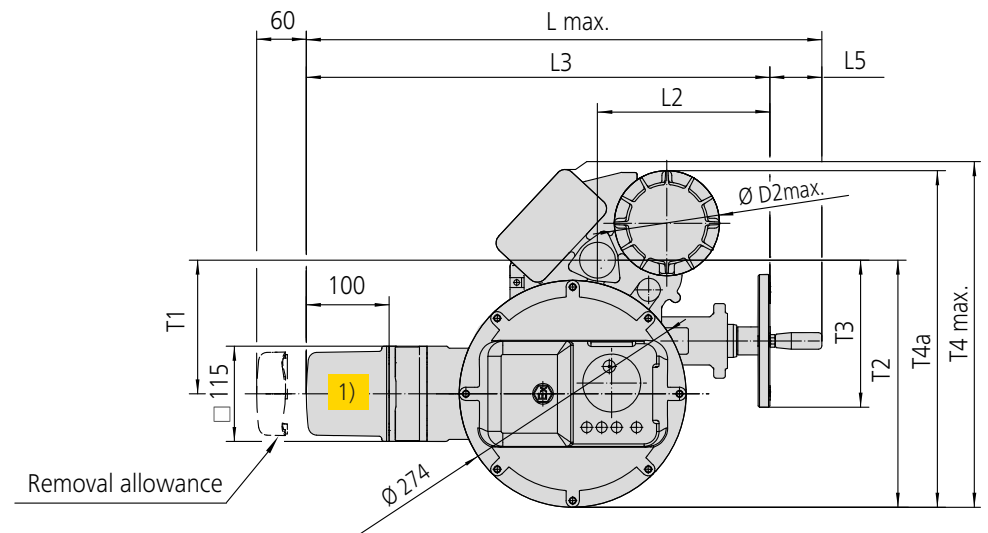
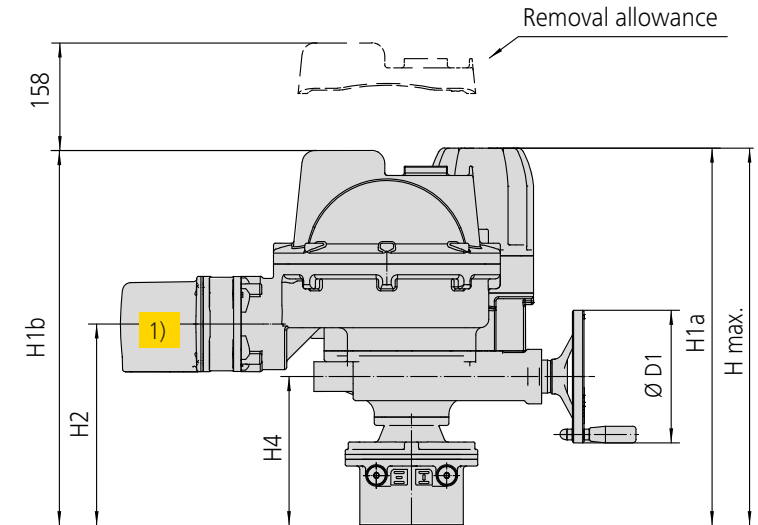

# Output drive forms

PART-TURN ACTUATOR x-matic

**DREHMO**  
VALVE ACTUATORS

Actuator DPIM(R) Ex	75/150/299			300/450		600/900		1200/1800	
Size DIN EN ISO 5211	F05	F07	F10	F10	F12	F12	F14	F14	F16
Maße [mm]									
d1	90	90	125	125	150	150	175	175	210
d2 <sup>18)</sup>	35	55	70	70	85	85	100	100	130
d3	50	70	102	102	125	125	140	140	165
d4	M6	M8	M10	M10	M12	M12	M16	M16	M20
d5	16			16		22		22	
d6	11			11		14		18	
h*	2.5			2.5		2.5		2.5	
h1	12			12		16		16	
h2	110			130		170		180	
thread depth d4	12	15	16	18	19	22	25	29	32
Lmax	40		66	50	82	61	102	75	127
l6	10			10		16		19	
l7	40			40		45		45	
l8	20			20		26		26	
l9	80			80		90		100	
l10	40			40		45		50	
l11	25			25		30		35	
l12	120			120		135		150	
l13	80			80		110		110	
l14	150			150		190		225	
r1	150			150		150		150	
r2	200			200		200		200	
r3	-			-		250		250	
r4	218			218		273		273	

Length unit: mm

\* Allowance for spigot is not available as standard. The spigot ring is a separate component, available as option.

## DIRECT MOUNTING

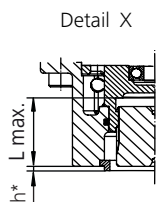
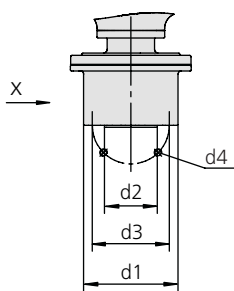

## FOOT AND LEVER

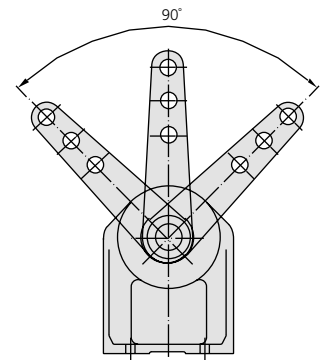
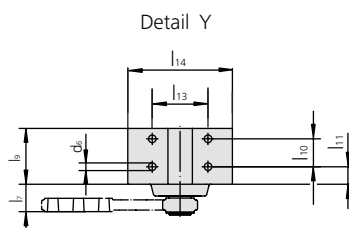
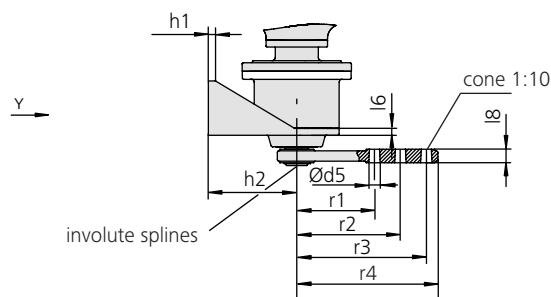

# Output drive forms

PART-TURN ACTUATOR x-matic

**DREHMO**  
VALVE ACTUATORS

Bore according to ISO 5211  
With keyway (form V)  
according to DIN 6885-1

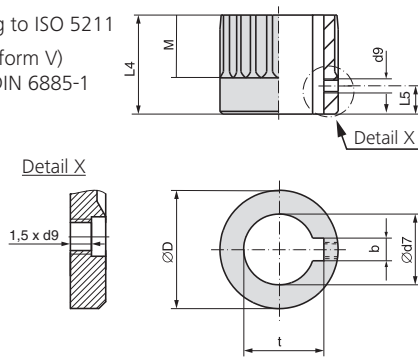

Dimensions	DPiM(R) Ex 75/150		DPiM(R) Ex 299		DPiM(R) Ex 300/450		DPiM(R) Ex 600/900		DPiM(R) Ex 1200/1800	
ISO 5211	F05	F07	F07	F10	F10	F12	F12	F14	F14	F16
Ø D	41.75		41.75		51.75		67.6		81.6	
b JS9 <sup>1)</sup>	6		6		8		10		14	
Ø d7 H8 <sup>2)</sup>	18		22		28		36		48	
Ø d7 max.	28		28		38		50		60	
d9 <sup>3)</sup>	M5		M5		M6		M6		M6	
L4	35		35		45	75	55	95	65	115
L5 <sup>3)</sup>	8		8		10		10		10	
M	20		20		30		40		47	40
t <sup>1)</sup>	20.8		24.8		31.3		39.3		51.8	

Square bore (form L/D)  
according to ISO 5211

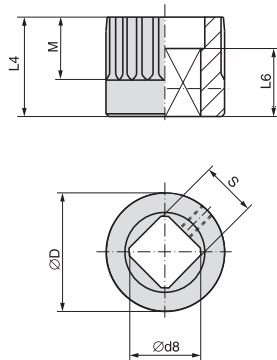

Dimensions	DPiM(R) Ex 75/150		DPiM(R) Ex 299		DPiM(R) Ex 300/450		DPiM(R) Ex 600/900		DPiM(R) Ex 1200/1800	
ISO 5211	F05	F07	F07	F10	F10	F12	F12	F14	F14	F16
Ø D	41.75		41.75		51.75		67.6		81.6	
Ø d8 min. <sup>2)</sup>	18.1		22.2		28.2		36.2		48.2	
Ø d8 max.	28.2		28.2		40.2 <sup>4)</sup>		48.2		60.2	
L4	35		35	60	45	75	55	95	65	115
L6 min.	30		30		30		30		40	
M	20		20		30		40		47	40
s H11 <sup>2)</sup>	14		17		22		27		36	
s H11 max.	22		22		30 <sup>4)</sup>		36		46	

Bore with two-flats (form H)  
according to ISO 5211

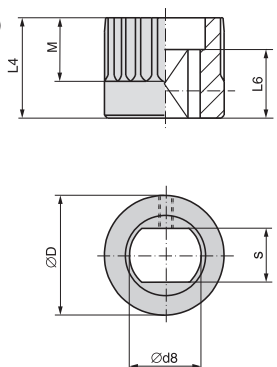

Dimensions	DPiM(R) Ex 75/150		DPiM(R) Ex 299		DPiM(R) Ex 300/450		DPiM(R) Ex 600/900		DPiM(R) Ex 1200/1800	
ISO 5211	F05	F07	F07	F10	F10	F12	F12	F14	F14	F16
Ø D	41.75		41.75		51.75		67.6		81.6	
Ø d8 min. <sup>2)</sup>	18.1		22.2		28.2		36.2		48.2	
Ø d8 max.	28.2		28.2		36.2		48.2 (48 <sup>5)</sup> )		60.2	
L4	35		35	60	45	75	55	95	65	115
L6 min.	25		25		25		30		40	
M	20		20		30		40		47	40
s H11 <sup>2)</sup>	14		17		22		27		36	
s H11 max.	22		22		27		36 (41 <sup>5)</sup> )		46	

Mounting position of coupling

X max.	3	4	5	8
Y max.	2	5	10	10

- 1) Dimensions depend on Ø d7, refer to DIN 6885-1
- 2) Recommended size according to ISO 5211
- 3) Thread with grub screw
- 4) According to DIN 79
- 5) According to DIN 475

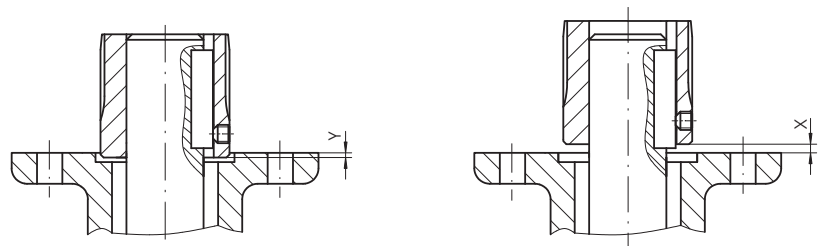

# Dimensions electrical connections

PART-TURN ACTUATOR x-matic

**DREHMO**  
VALVE ACTUATORS

„KLKA“

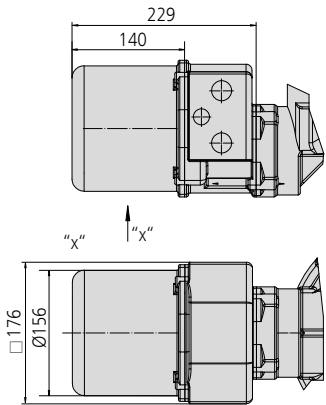

„S“

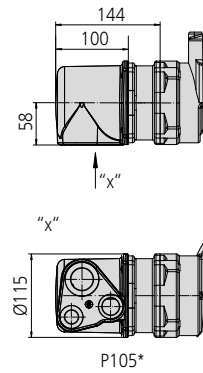

„SH“

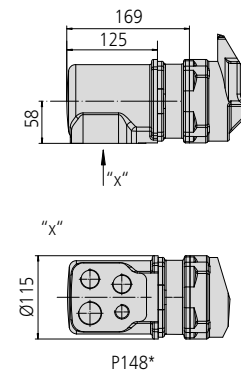

„SB“

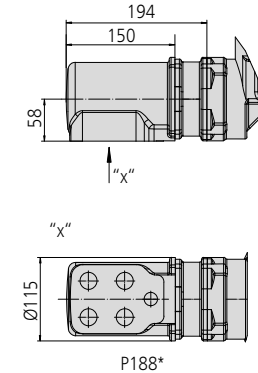

„KT Ex e“

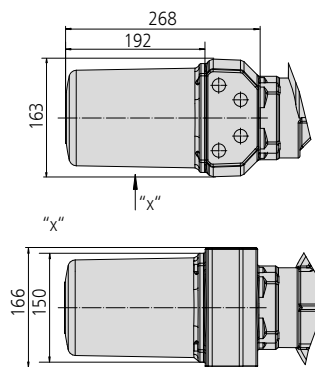
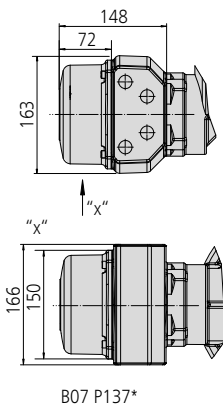
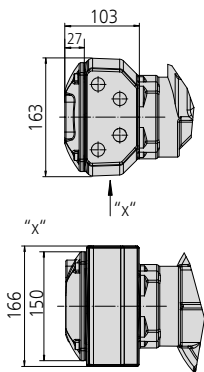

„KT Ex d“

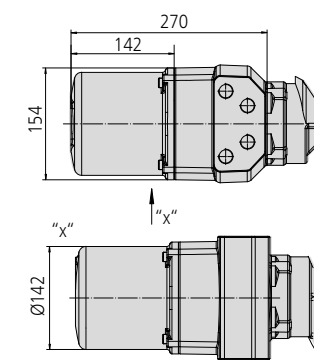
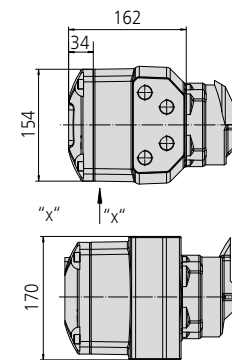

„KES Ex d“

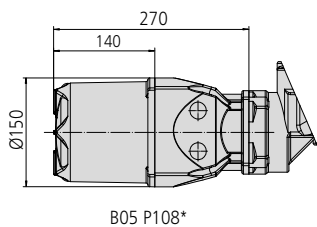

„KES Ex e“

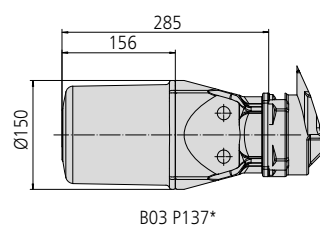

\* Thread combination code  
Alternative thread combinations  
available as option